

# HabaCHAIN®

Habasit – Solutions in motion

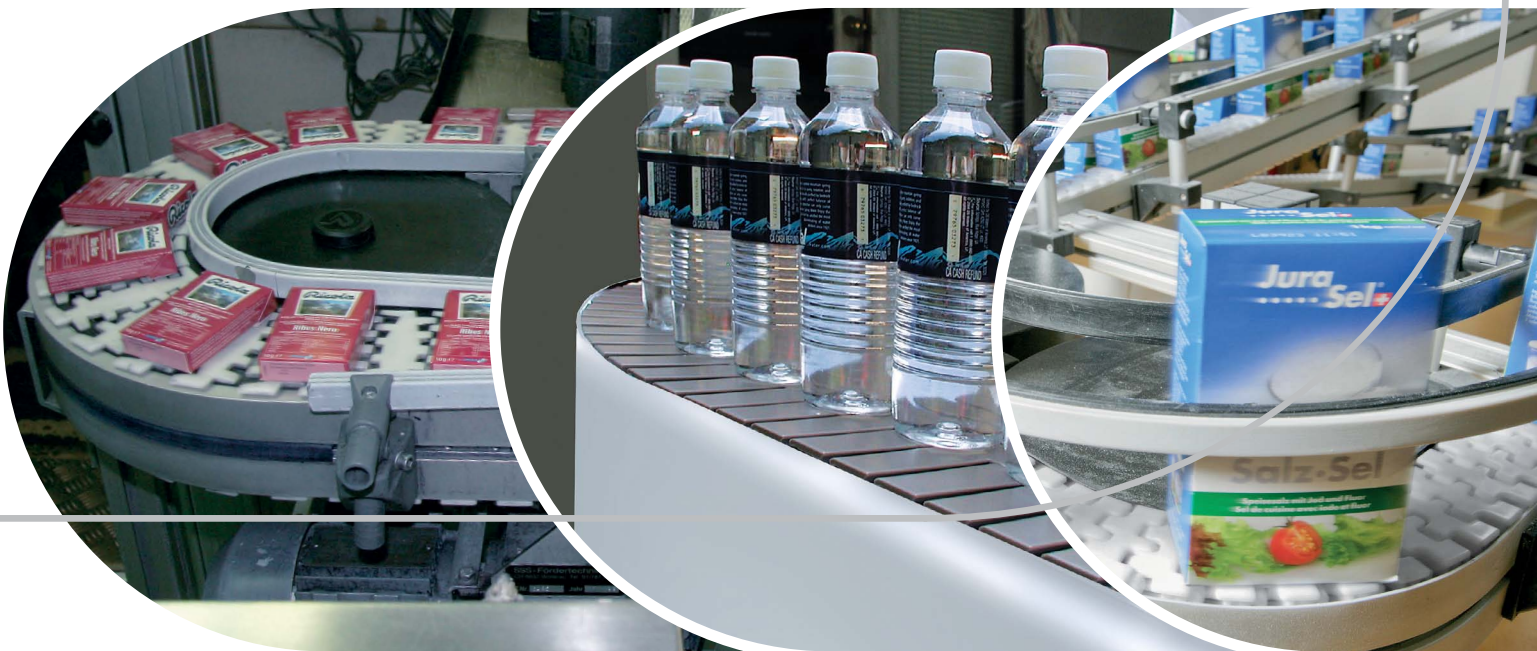

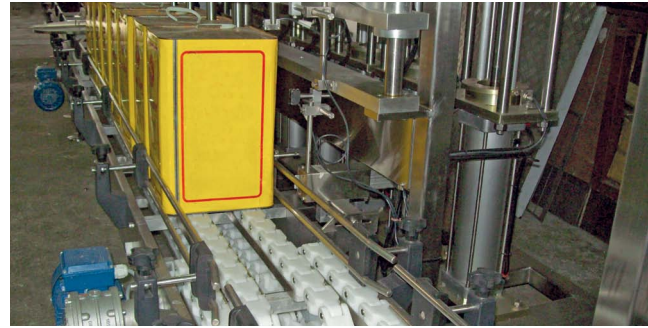

**Your solutions partner**

Habasis is committed to understanding your design parameters and application needs. After reviewing your requirements, our engineering staff will suggest the best solution for each application.

**Application / Engineering support**

Habasis's knowledgeable engineering staff are available to assist you with all your application needs. Habasis engineers will provide assistance with:

- Selection recommendations
- Application engineering evaluations
- Product performance analysis
- Product handling evaluations
- Retrofit / Crossover recommendations
- New product development opportunities



**Global expertise**

With over 60 years of experience in the conveying industry and the most innovative and largest product line offering, Habasis is a leader in the conveyor belting industry worldwide. Habasis is dedicated to meeting your conveying needs with state-of-the-art, high quality products and services.



**The HabaCHAIN® product line**

The HabaCHAIN® product line is designed, produced and serviced by a worldwide leader in conveyor belting – Habasis. HabaCHAIN® products offer world class quality and innovation combined with excellent reliability and cost efficiency.

HabaCHAIN® products are available in straight running and side-flexing versions.

HabaCHAIN® is completely compatible with industry standards which allows for easy retrofits without conveyor modifications.

HabaCHAIN® products are available in a wide variety of problem solving materials such as, low friction, enhanced chemical resistance, anti-static, high temperature and magnetic.

**Industries served**

- Beverage • Canning • Bakery • Snack foods
- Meat - poultry - fish • Packaging • Dairy
- Electronics • Pharmaceuticals • Automotive
- Materials handling • Cardboard • Tissue • Textiles



**Features and benefits:**

- High Tensile Strength : *less downtime, maximize conveyor line layouts.*
- World Class Quality : *insures optimum product handling.*
- Low Friction Materials : *excellent for high speed applications.*
- Bevel Edges : *product stability over multiple strand conveyance.*
- High Friction Inserts : *unique product conveying solutions.*
- Wide Range of Specialty Materials : *total coverage for all your application needs.*

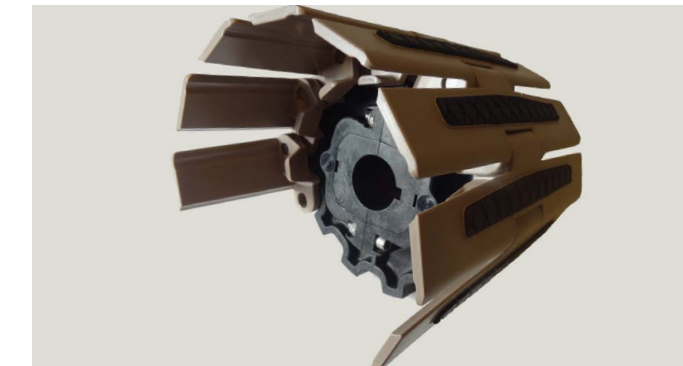
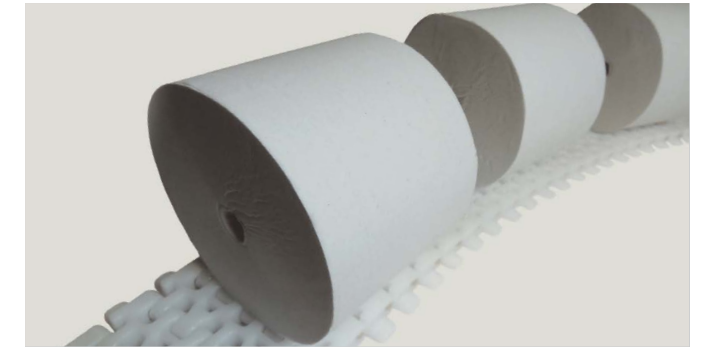

**Innovative patented products from Habasis:**

- Multi-hub sprockets and idler design : *unique design concept allows for separating the tooth segment from the hub/bore insert. This provides flexibility to optimize inventory while reducing carrying cost.*
- 7100 chain design : *increased versatility through a two-piece chain.*
- Low-backline Pressure (LBP) solution : *reduced back pressure, noise reduction, better load stability and reduced vibration.*
- Insert of special sliding block for LBPs in place of the intermediate shaft : *better stability, noise reduction, low product residual push.*
- Unique magnetic solution for improved tracking : *noise reduction, better cleanability.*

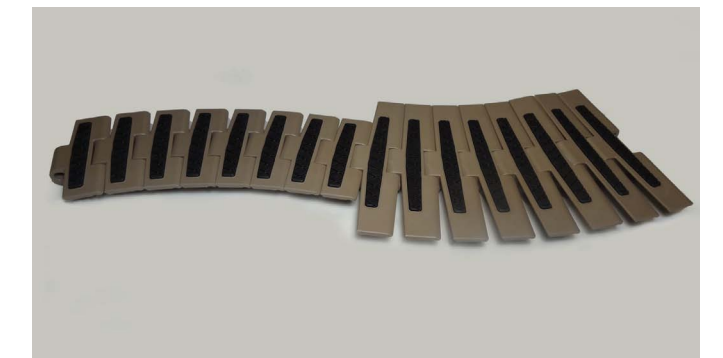
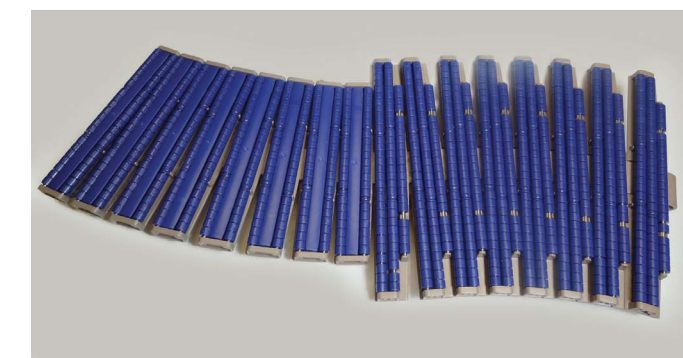

**Quick Ship Program**

The Quick Ship Program represents a selection of chain that is in stock and ready to ship immediately. If you order by 1:00pm EST, Habasit will ship it the same day with no expediting fees. For complete product availability, please contact Habasit today.



- Prompt shipping
- Guaranteed in stock
- Quality products
- On-time delivery
- Tested and proven products

Chain	Widths (inches)										
	2.48	2.50	3.25	3.30	4.00	4.05	4.50	6.00	7.50	10.00	12.00
<b>Slat Top Plastic Chains</b>											
C0820 LF		•	•		•		•	•	•		
C0821 LF									•	•	•
C0821 PT									•	•	•
C0831 LF			•				•		•		
C0879 LF			•				•				
C0880 Tab LF			•				•		•		
C0880 Bevel LF			•				•		•		
C0882 Tab LF							•		•	•	
C1061 Tab LF				•							
<b>Low Back Pressure Chains</b>											
C0821 LF									•	•	•
C0821 PT									•	•	•
C0882 TAB LF									•	•	
<b>Flexi Chains</b>											
C7100 PT	•		•				•				

  

Case Chains	Availability	Case Chains	Availability	Case Chains	Availability	Chain	Availability
C0040 DP	•	C1100 NY	•	C1200 DP	•	C1210 Tab HT	•
C0060 DP	•	C1150 HT	•	C1200 HT	•	C1700 LF	•
C1100 DP	•	C1150 PC	•	C1210 Tab DP	•	C1701 Tab LF	•

• = Available for Quick Ship Program.  
Slat Top Steel Chains and Snap on Chains are available. Please contact Customer Care for more details.

**Low Friction**

Habasit's "Low Friction" chain material delivers friction properties that meet or exceed those offered by other high performance materials at a premium price. This allows customers to optimize performance at a competitive price so the savings go right to your bottom line.

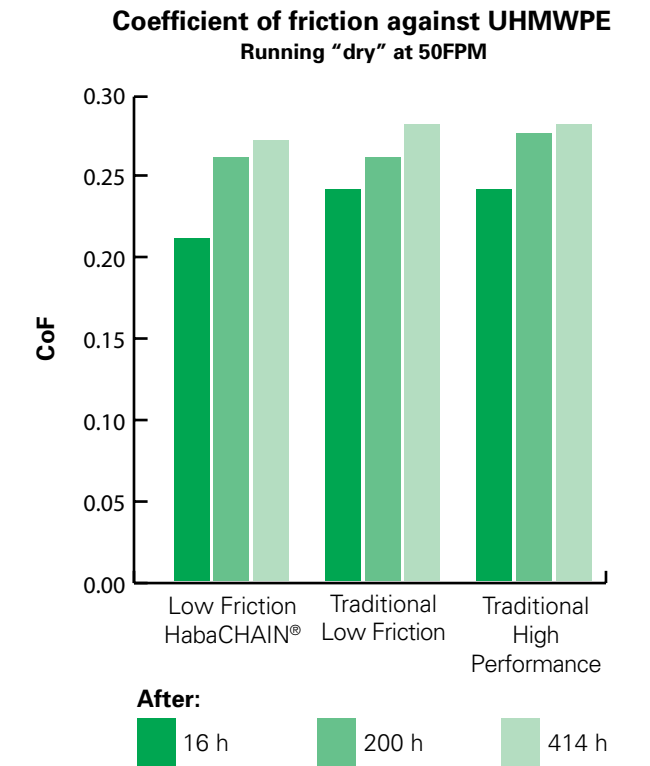
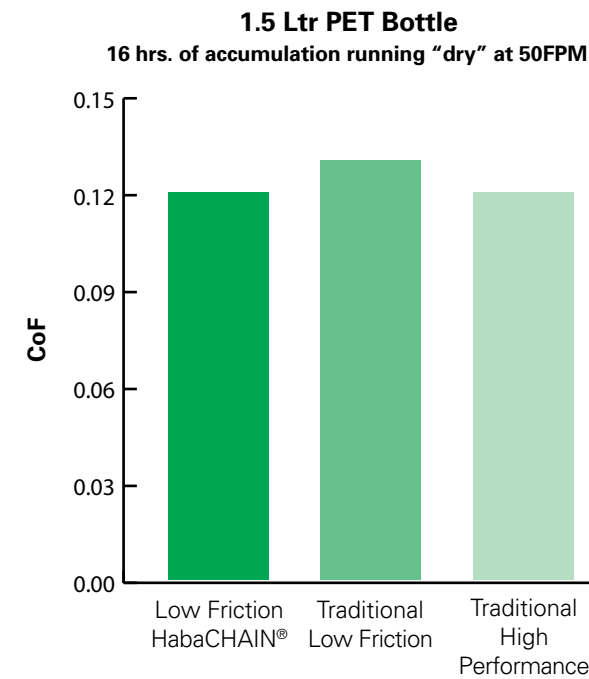

**HabaCHAIN® Multi-Hub: Sprockets and Idlers**

**Multi-Hub**

Habasit's Patented Multi-Hub Split Sprocket and Split Idler Wheel design allows customers the flexibility to interchange sprocket tooth and idler rims with a wide variety of hub inserts. They are available with various bore sizes and configurations which provides flexibility to optimize inventory while reducing carrying cost.

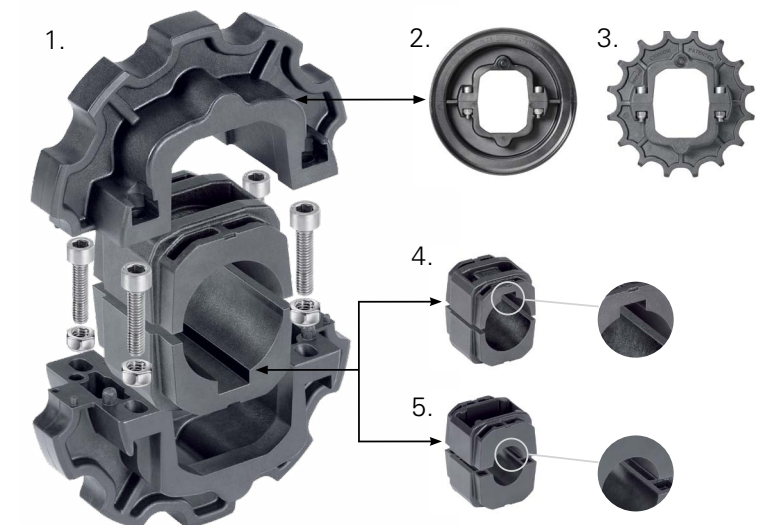

1. Complete Multi-Hub Split Sprocket
2. Interchangeable Multi-Hub Split Idler Wheel Rim
3. Interchangeable Multi-Hub Split Sprocket Tooth Rim
4. Interchangeable Multi-Hub Insert with round bore, keyway and setscrew for drive sprocket applications
5. Interchangeable Multi-Hub Insert with plain round bore for idler sprocket applications

## Over Molds

Habasis's over mold capability allows us to provide high friction inserts in a wide range of profiles to support your conveying application needs. These high friction inserts are molded directly into the chain for optimum performance and durability.

Habasis's high friction inserts are available in different hardness and can be adapted to almost any HabaCHAIN® style to handle the following applications:

- Inclines
- Declines
- Case/product turning
- Case/product orientation

For further information on availability of standard or custom inserts, please contact Habasis.



# High Quality Chain

## Product Testing

Habasis has invested heavily to make sure our chains exceed industry standards. The quality that you have come to expect from Habasis can be found in our chains. Habasis insures the highest quality chains through rigorous testing at the Habasis Innovation Center. These tests include:

- Long term friction test
- Noise test
- Radius pv-limit test
- Dynamic sprocket test
- Dynamic fatigue test
- Incline angle measurement
- Incline test loop
- Lifetime and abrasion test
- Impact test

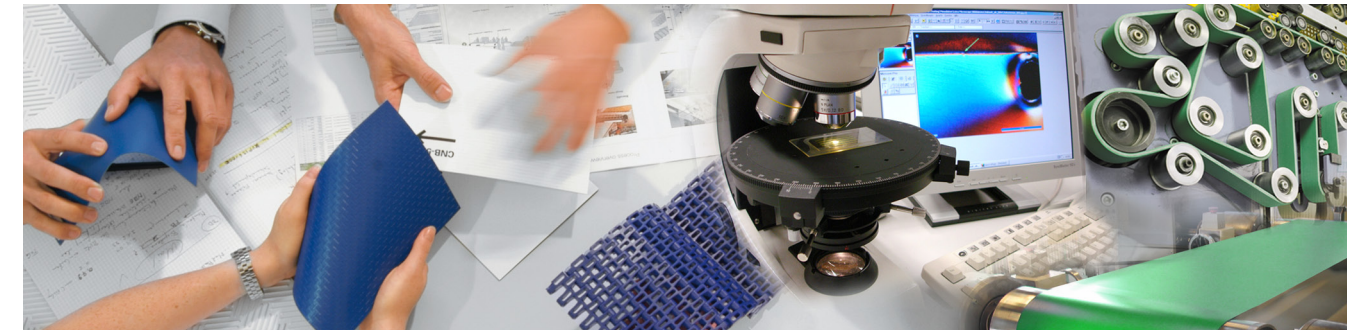
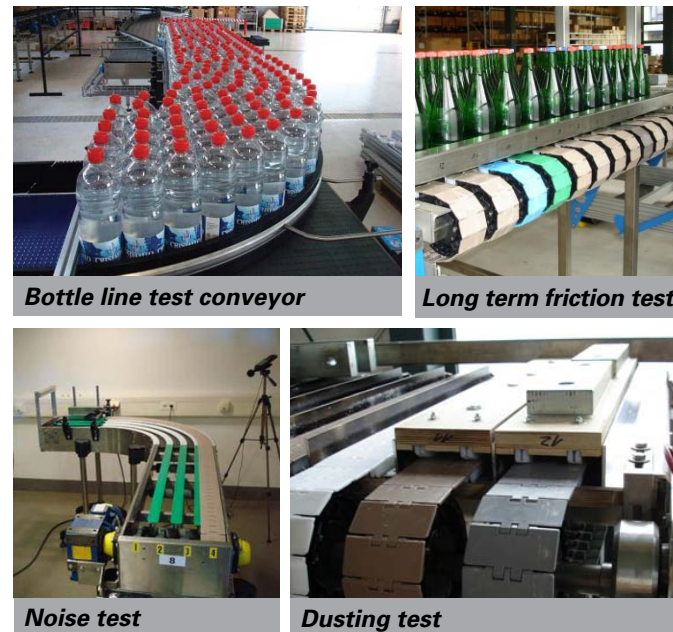

## Customers first

At Habasis we understand that our success depends on your success. This is why we offer solutions, not just products; partnership, not just sales. Since our foundation in 1946, Habasis has brought this understanding of customer needs to life every day and for every application. That's why we're the No. 1 in belting today. Worldwide. Learn more on [www.habasis.com](http://www.habasis.com)

## Committed to innovation

Habasis is strongly committed to the continuous development of innovative, value-added solutions. Over 3% of our staff are dedicated exclusively to R&D, and our annual investment in this area exceeds 8% of turnover.

## Certified for quality

We deliver the highest quality standards not only in our products and solutions, but also in our employees' daily work processes. Habasis AG is certified according to ISO 9001:2000.



## Worldwide leading product range

Habasis offers the largest selection of belting, conveying, processing and complementary products in the industry. Our response to any request is nothing less than a specific, tailor-made solution.

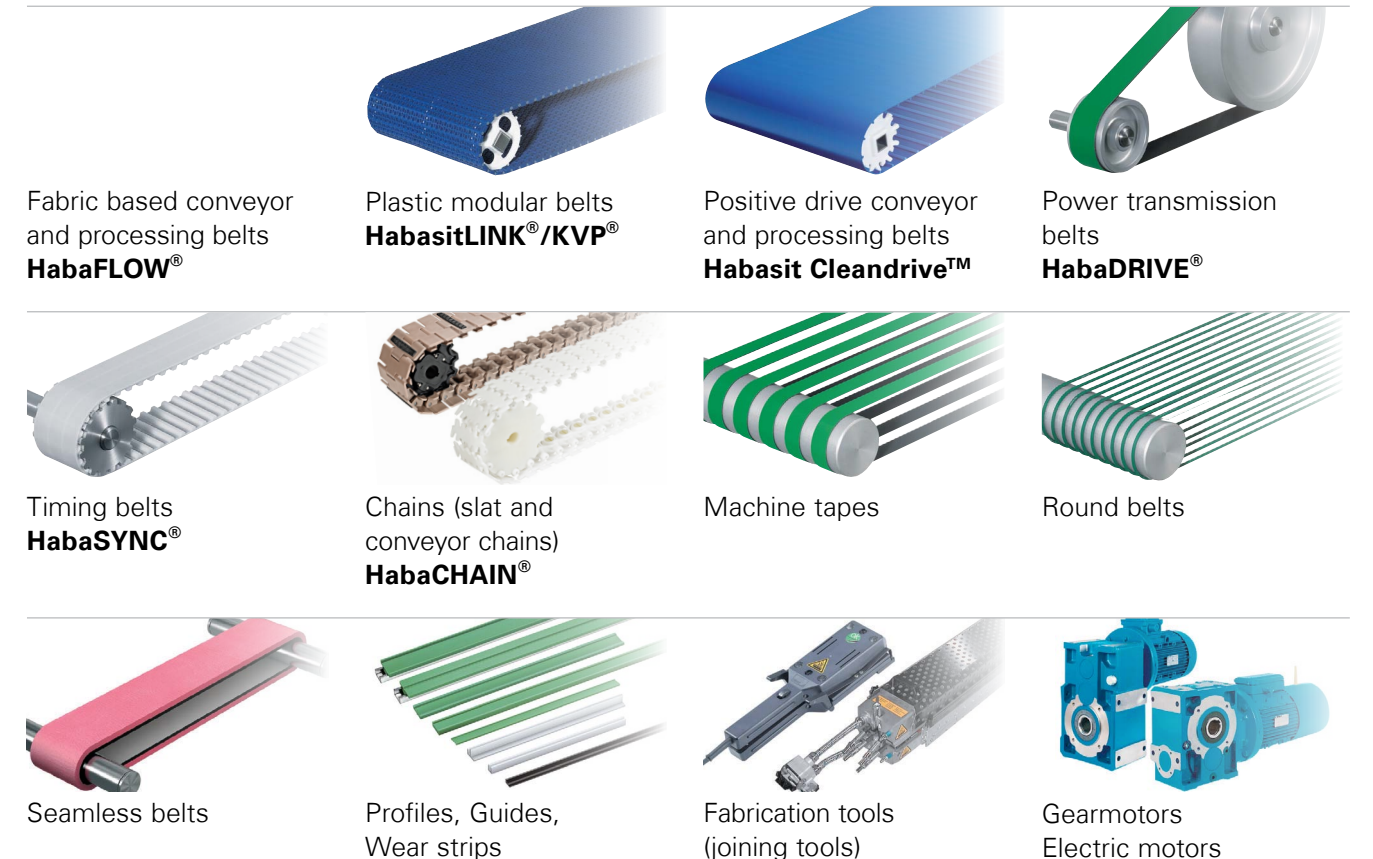

**Austria**

Habasit GmbH, Wien  
Phone: +43 1 690 66  
www.habasit.at

**Belgium**

Habasit Belgium N.V., Zaventem  
Phone: +32 27 250 430  
www.habasit.be

**Canada**

Habasit Canada Ltd., Oakville  
Phone: +1 905 827 41 31  
www.habasit.ca

**China**

Habasit East Asia Ltd., Hong Kong  
Phone: +85 221 450 150  
www.habasit.com.hk

**Habasit (Shanghai) Co., Ltd.**

Shanghai  
Phone: +8621 5488 1228  
Phone: +8621 5488 1218  
www.habasit.com.hk

**France**

Habasit France S.A.S., Mulhouse  
Phone: +33 389 338 903  
www.habasit.fr

**Germany**

Habasit GmbH  
Eppertshausen  
Phone: +49 6071 969 0  
www.habasit.de

**India**

Habasit-lakoka Pvt. Ltd., Coimbatore  
Phone: +91 422 262 78 79  
www.habasitlakoka.com

**Italy**

Habasit Italiana SpA  
Customer Care:  
Phone: 199 199 333  
For int. calls: +39 0438 911 444  
www.habasit.it

**Japan**

Habasit Nippon Co. Ltd., Yokohama  
Phone: +81 454 760 371  
www.habasit.co.jp

**Netherlands**

Habasit Netherlands BV, Nijkerk  
Phone: +31 332 472 030  
www.habasit.nl

**New Zealand**

Habasit Australasia Ltd., Hornby  
Phone: +64 3348 5600  
www.habasit.co.nz

**Norway**

Habasit Norge A/S, Oslo  
Phone: +47 815 58 458  
www.habasit.no

**Poland**

Habasit Polska Sp. z o.o.,  
Dąbrowa Górnicza,  
Phone: +48 32639 02 40  
www.habasit.pl

**Russia**

Habasit Ltd., St. Petersburg  
Phone: +7 812 600 40 80  
www.habasit.ru

**Singapore**

Habasit Far East Pte. Ltd., Singapore  
Phone: +65 686 255 66  
www.habasit.com.sg

**Spain**

Habasit Hispanica S.A.,  
Barberà del Vallès  
Phone: +34 937 191 912  
www.habasit.es

**Sweden**

Habasit AB, Hindas  
Phone: +46 30 122 600  
www.habasit.se

**Switzerland**

Habasit GmbH, Reinach  
Phone: +41 61 577 51 00  
www.habasit.ch

**Taiwan**

Habasit Rossi (Taiwan) Ltd.  
Taipei Hsien  
Phone: +886 2 2267 0538  
www.habasit.com.tw

**Turkey**

Habasit Kayis San. Ve Tic. Ltd. Sti.  
Yenibosna - Bahcelievler - Istanbul  
Phone: +90 212 654 94 04  
www.habasit.com.tr

**Ukraine**

Habasit Ukraina, Vinnica  
Phone: +38 0432 58 47 35  
www.habasit.ua

**United Kingdom and Ireland**

Habasit Rossi (UK) Ltd., Silsden  
Phone: +44 844 835 9555  
www.habasitrossi.co.uk

**USA**

Habasit America  
Conveyor belts, power  
transmission belts, gearmotors  
Suwanee, Georgia  
Phone: +1 800 458 6431  
www.habasitamerica.com

Habasit America  
Seamless belts, timing belts  
Middletown, Connecticut  
Phone: +1 860 632 2211  
www.habasitamerica.com

**Rossi** is one of Europe's largest manufacturers of gear reducers, gearmotors, inverters, standard and brakemotors, and is a member of the Habasit Group.

Rossi S.p.A.  
Via Emilia Ovest 915/A  
41123 Modena – Italy  
Phone: +39 059 33 02 88  
www.rossi-group.com  
info@rossi-group.com

**Product liability, application considerations**

If the proper selection and application of Habasit products are not recommended by an authorized Habasit sales specialist, the selection and application of products, including the related area of product safety, are the responsibility of the customer. All indications / information are recommendations and believed to be reliable, but no representations, guarantees, or warranties of any kind are made as to their accuracy or suitability for particular applications. The data provided herein are based on laboratory work with small-scale test equipment, running at standard conditions, and do not necessarily match product performance in industrial use. New knowledge and experiences can lead to modifications and changes within a short time without prior notice. BECAUSE CONDITIONS OF USE ARE OUTSIDE OF HABASIT'S AND ITS AFFILIATED COMPANIES' CONTROL, WE CANNOT ASSUME ANY LIABILITY CONCERNING THE SUITABILITY AND PROCESS ABILITY OF THE PRODUCTS MENTIONED HEREIN. THIS ALSO APPLIES TO PROCESS RESULTS / OUTPUT / MANUFACTURING GOODS AS WELL AS TO POSSIBLE DEFECTS, DAMAGES, CONSEQUENTIAL DAMAGES, AND FURTHER-REACHING CONSEQUENCES.

Habasit America  
805 Satellite Boulevard  
Suwanee, GA  
Phone (800) 458-6431  
Fax (800) 422-2748  
E-mail info.america@us.habasit.com  
www.habasitamerica.com